

# Bradshaw Specification

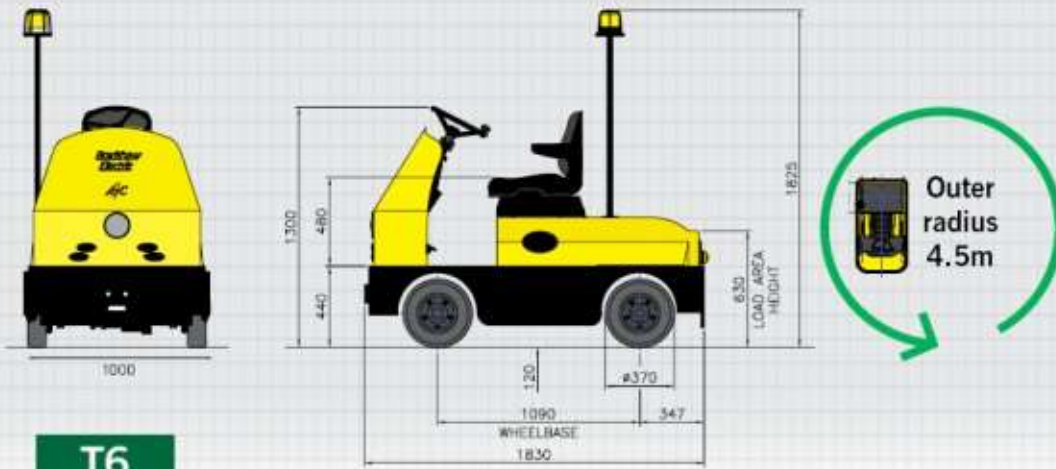

**T6**

Power unit	Battery
Towed load capacity	7,000kg
Unladen Vehicle weight	1120kg
Axle load, front/rear	45% / 55%
Tyres, front/rear	15 + 4.5 + 8
Wheels, front/rear wheel drive	2/2
Towing coupling height	To Suit Application
Travel speed,max	8mph / 13kph
Brakes	Front / Rear - on all wheels
Parking Brake	Automa
Drive motor, 60 minute rating	4kw
Battery Capacity @ 48V	upto 345 Amp Hours
Battery weight (±5%)	upto 500kg