

Bradshaw Specification

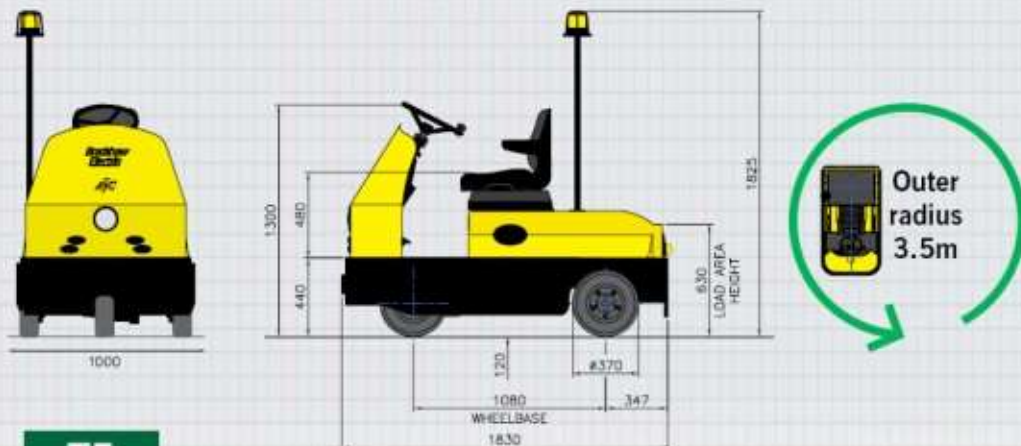

T5

| | |
|--------------------------------|------------------------------|
| Power unit | Battery |
| Towed load capacity | 6,000kg |
| Unladen Vehicle weight | 1120kg |
| Axle load, front/rear | 45% / 55% |
| Tyres, front/rear | 15 + 4.5 + 8 |
| Wheels, front/rear wheel drive | 1/2 |
| Towing coupling height | To Suit Application |
| Travel speed,max | 8mph / 13kph |
| Brakes | Front / Rear - on all wheels |
| Parking Brake | Automatic |
| Drive motor, 60 minute rating | 4kw |
| Battery Capacity @ 48V | upto 315 Amp Hours |
| Battery weight (±5%) | upto 500kg |
| Type of drive control | AC Controller |